



SITE REQUIREMENTS:

- 6" minimum thick concrete pad or footers
- Layout per approved submittal

REQUIRED TOOLS:

- Hammer drill
- Manual Blow-out pump or compressed air to clean out drilled holes in concrete.
- Concrete Drill bit: Refer to Hilti instructions to determine size for HVU Capsule Adhesive Anchors use.
- Standard drill and impact drill driver
- Rubber mallet and dead-blow hammer
- Level
- Hand tools
 - 5/16" hex head drive
 - 15/16" socket and or wrench
 - 3/4" socket and or wrench
- Torque Wrench, up to 150 ft-lbs

CityScapes[®]
ARCHITECTURAL INNOVATIONS

877-727-3367

4200 LYMAN COURT
HILLIARD, OH 43026

CITYSCAPESINC.COM





REV. 12/21



COVRIT INCLUDED PARTS

Item	Description
	Corner post with welded base plate
	Corner post cover
	Mid-span post with welded mounting flanges (when selected)
	Mid-span post cover
	Bottom rail spacer
	Top rail *(PlankWall Only)
	Bottom rail *(PlankWall Only)
	Top rail *(Metal & ABS Only)
	Bottom rail *(Metal & ABS Only)
	Base plate drilling guide





Item	Description
	<ul style="list-style-type: none"> Hilti HAS-E Threaded Rod Hilti HVU Capsule Adhesive Anchors
	Post cap retainer
	Post caps
	Covrit name plate
	Bolt cover
	5/8" Nut
	1/2" - 13 Nylock nut
	5/8" Washer
	1/2" Washer
	5/8" Lock washer

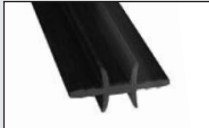

COVRIT INCLUDED PARTS CONTINUED

Item	Description
	HAS-E threaded rod *(See submittal for size requirements)
	1/2" - 13 x 1" gate hinge bolt
	1/2" - 13 x 3" gate hinge bolt
	Tek screw 10-16 x 3/4" SS

Item	Description
	Tek screw 12-14 x 3" (Climcoat)
	Pre-cut and grooved planks *(PlankWall Only)
	Aluminum stiffeners *(PlankWall Only)
	Selected infill panel *(Metal & ABS Only)

TOUGHGATE INCLUDED PARTS

Item	Description
	Pre-assembled door
	Integrated corner gate post with welded base plate
	Gate handle kit (4 Phillips flat head screws included)
	Gate latch

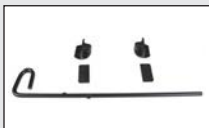
Item	Description
	Gate latch Kit
	Barrel hinge (when selected)
	Drop pin kit

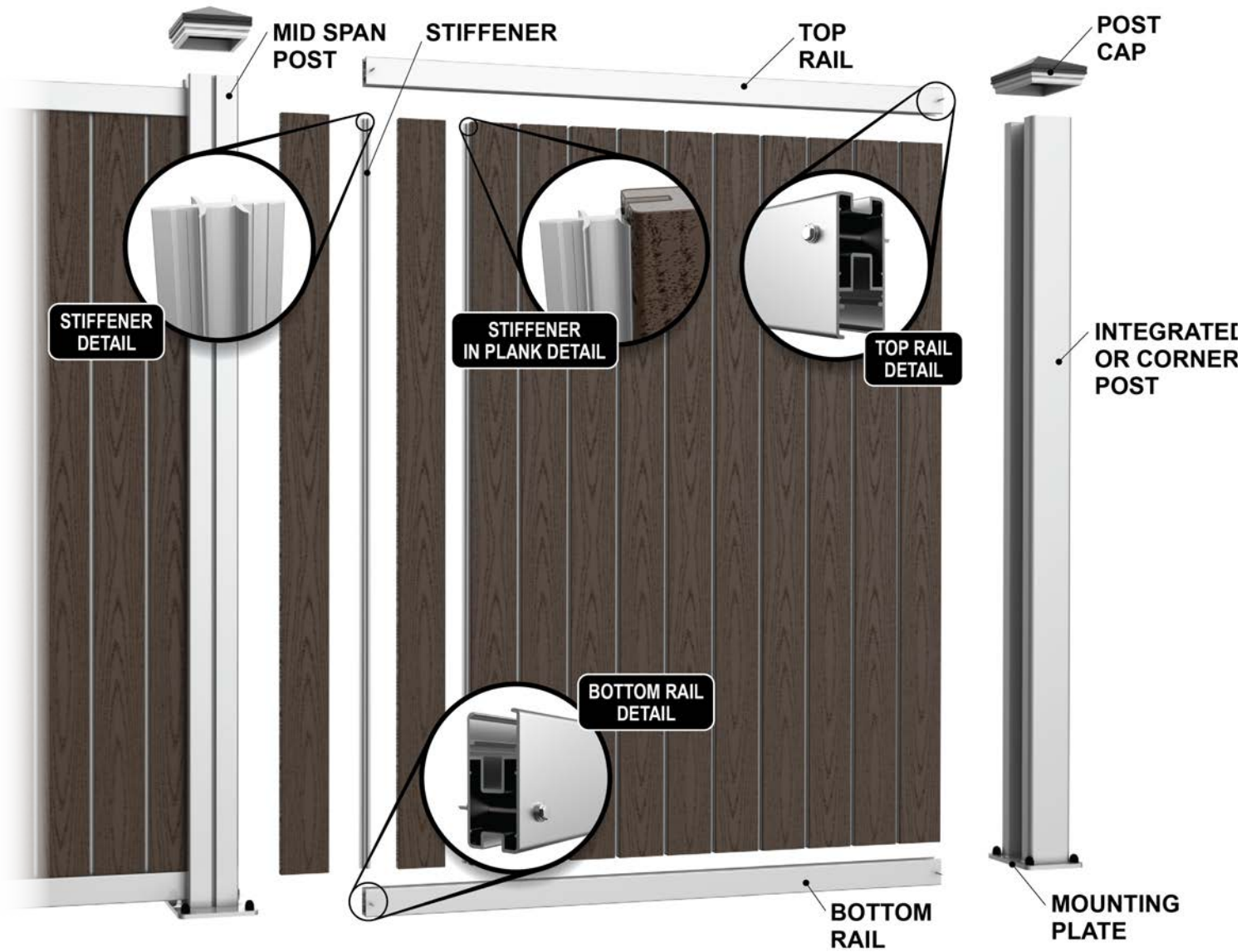

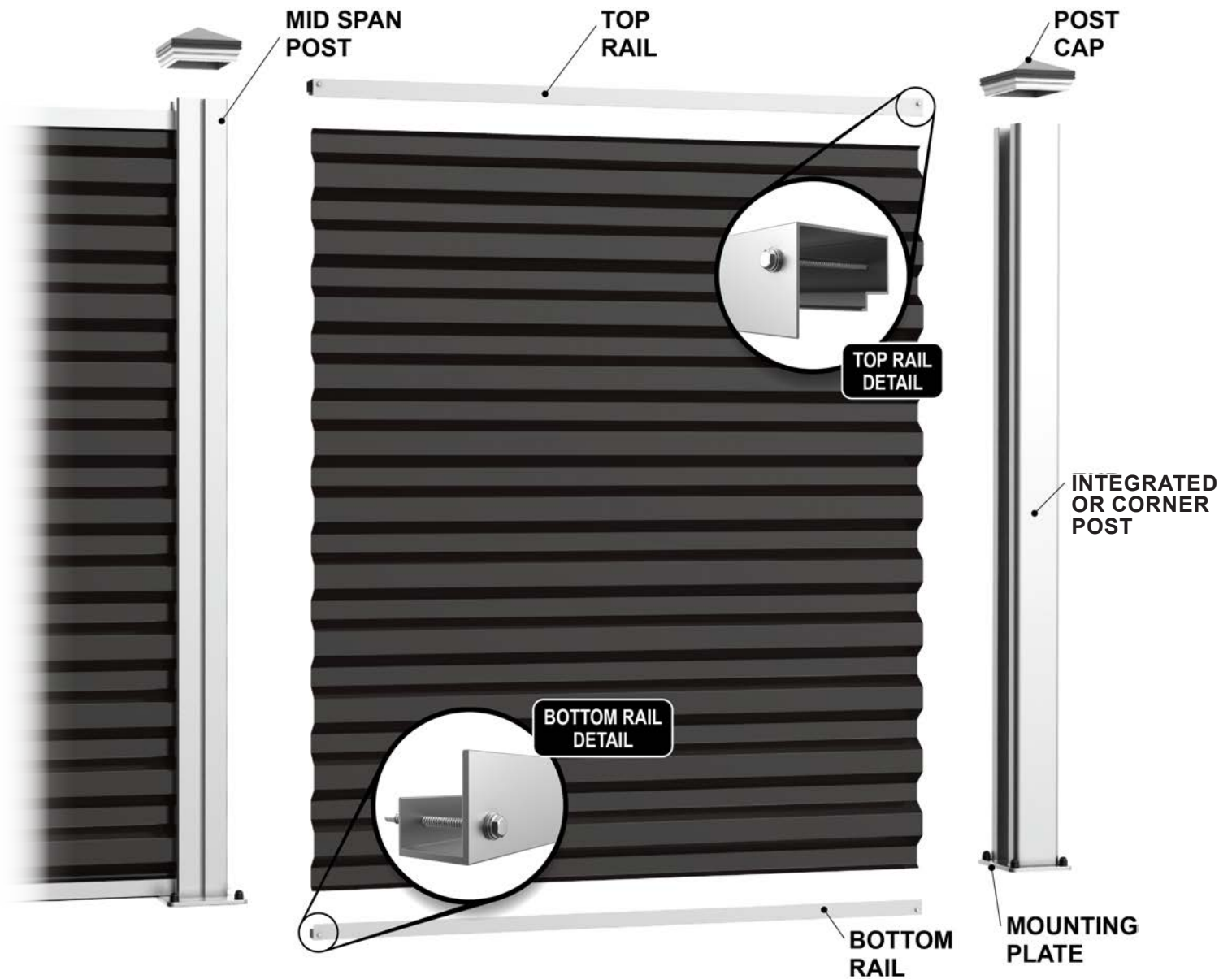

1. Start with concrete (either poured footers or a slab) a minimum of 6" thick.
2. Measure and mark the enclosure/wall layout according to the approved submittal package.
3. Using the supplied **Base Plate Drilling Guide** and a Hilti-approved drill to drill holes for the post.
 - Note: Follow the instructions in the Hilti Package to set four bolts and anchors using quick-set epoxy.
4. Once bolts are set, place one 5/8" nut and washer on each bolt, in that order.

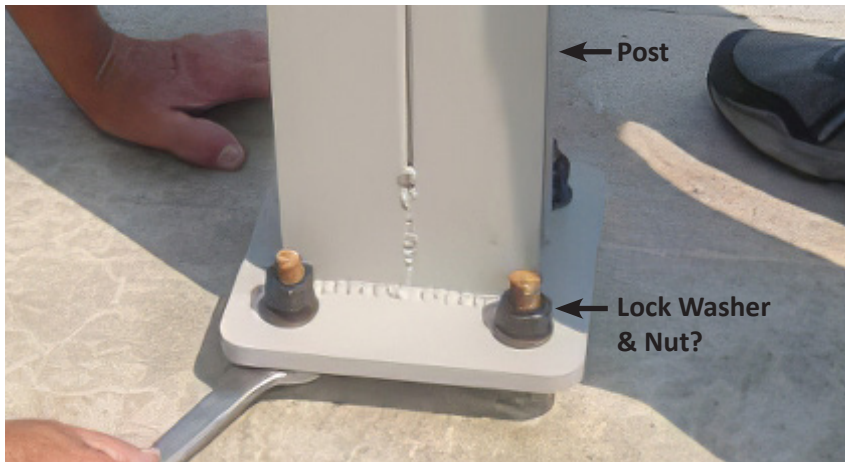
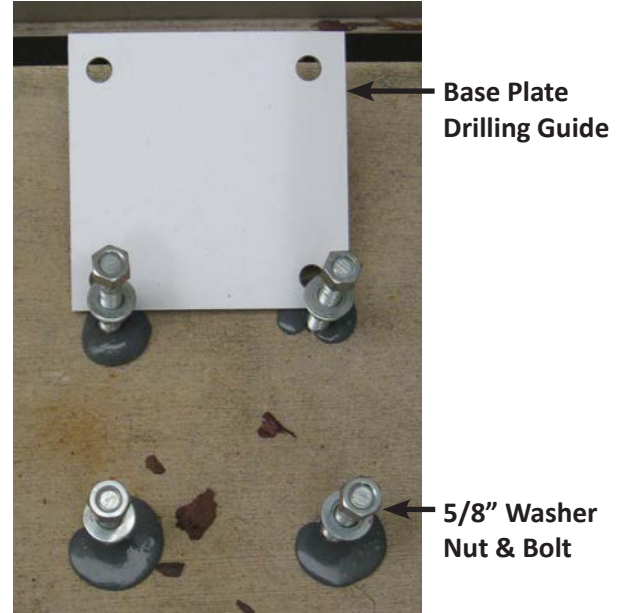

5. Place the post, with base plate, on the four bolts as shown on submittal.
6. Add one 5/8" lock washer and one nut to each bolt & loosely tighten.

7. Measure and position mid span post as shown on approved submittal. Verify fit by inserting bottom rail piece for that section.
 - **Note: ensure 1/4" gap between posts and ends of bottom rail.**
8. Mark and drill holes for bottom rail Tek screws.
9. Repeat steps 3-8 to secure posts
 - At this point you could install the bottom rail for this section or continue to set all posts. For instruction purposes, we will set all posts then install bottom rails.



10. Repeat post installation procedures for remaining mid span, corner or end posts, as shown on approved submittal sheet.
11. Use a level to adjust levelness and plumbness of the posts. Adjustments are done with the nuts underneath the base plate.
12. With all posts level and plumb, install bottom rail with the large, lineal opening facing up. Using tek screws, screw the bottom rail to the flat on the mid span post.
 - **Note: Verify rail is level prior to securing with screw**
 - **Note: Ensure a 1/4" gap is maintained to allow for the insertion of post covers.**
13. Install remaining bottom rails and secure as described above.
14. Tighten hex nuts to proper torque rating per Hilti instructions.

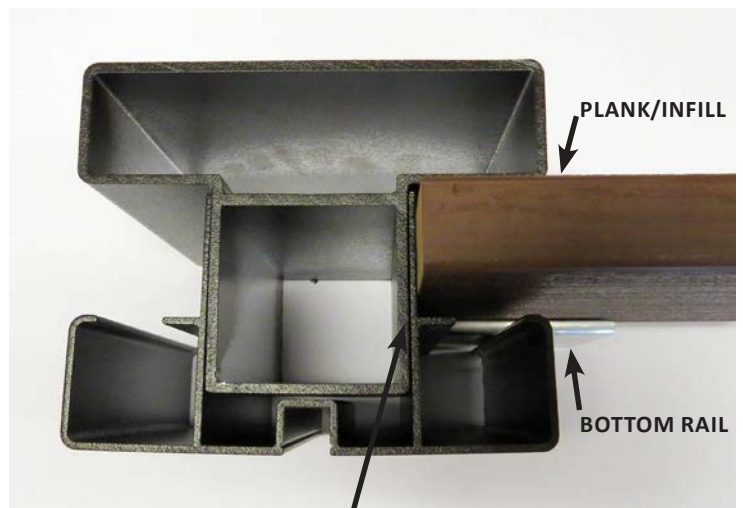
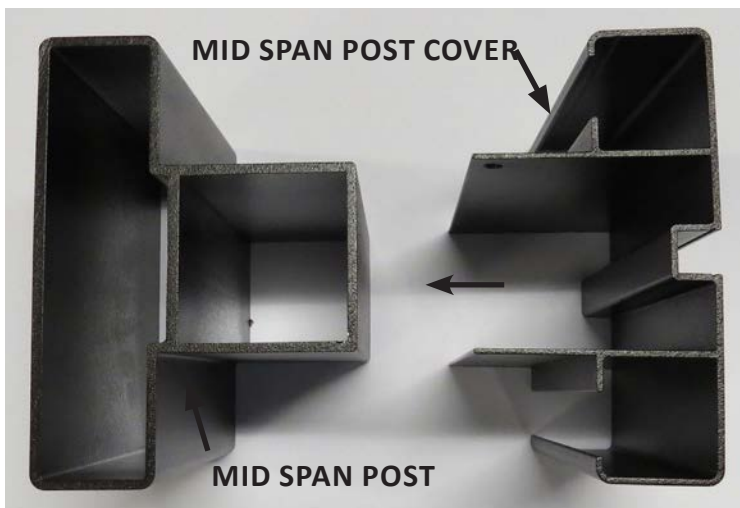

ENSURE A 1/4" GAP IS MAINTAINED BETWEEN PLANK/INFILL & POST



15. Use the approved submittal to verify plank orientation (vertical or horizontal)
16. Insert long side (for horizontal configuration), or end (for vertical configuration) of pre-cut plank into the wide opening of the installed bottom rail.
 - **Note: For vertical, the first plank should be positioned at one end of the bottom rail leaving the same ¼" gap.**



17. Use a rubber mallet or dead-blow hammer to fully seat the plank into the bottom rail.
18. Insert one end of the aluminum stiffener in the pre-cut groove of the seated plank. Use the rubber mallet or dead-blow hammer to fully seat the stiffener into the plank.
19. Align pre-cut groove of the next plank with the installed aluminum stiffener. Use the rubber mallet or dead-blow hammer to fully seat the plank onto stiffener.
 - **Note: For vertical installation, you may need to continue to tap the top of the planks to ensure they are seated into the bottom rail.**



20. Repeat plank and stiffener steps until all planks for the section have been installed.
 - **Note: All planks should be even across the top. If not, tap with rubber mallet or dead-blow hammer to fully seat the plank in the bottom rail.**

*** FOR VERTICAL INSTALLATION, TAP THE TOP OF THE VERTICAL PLANKS TO ENSURE THEY ARE SEATED INTO THE BOTTOM RAIL AND ENSURE STIFFENERS AND PLANKS ARE FULLY ENGAGED**

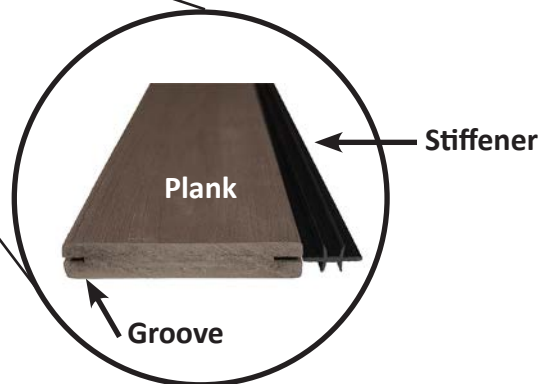

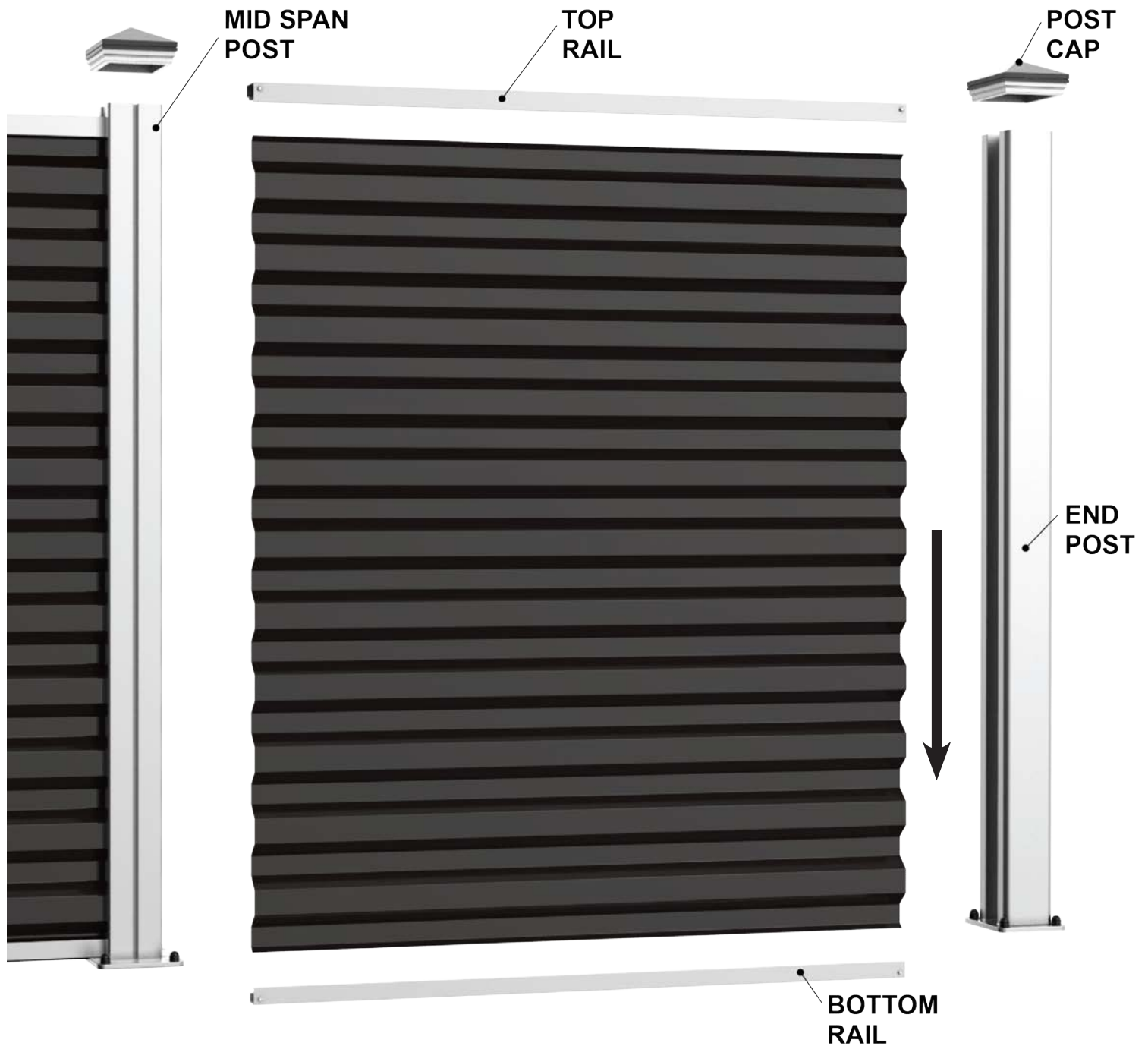

15. Insert pre-cut Metal/ABS panel into the opening of the installed bottom rail.
- **Note:** *Metal & ABS panels are typically secured to posts with the provided Tek Screws*



21. Install the top rail by aligning the large, lineal opening on top of the installed planks.
 - **Note: (PlankWall only) Use a rubber mallet or dead-blow hammer to fully seat the top rail on the planks.**
22. Use a level to verify top rail is level, adjust as needed.



23. Secure the top rail to the posts with Tek screws.
24. Repeat installations instructions for remaining Covrit wall sections.

25. Align post cover over the back of corresponding post (i.e. mid span or corner)

26. Ensure cover is fully seated on post

AERIAL VIEW OF POST & POST COVER

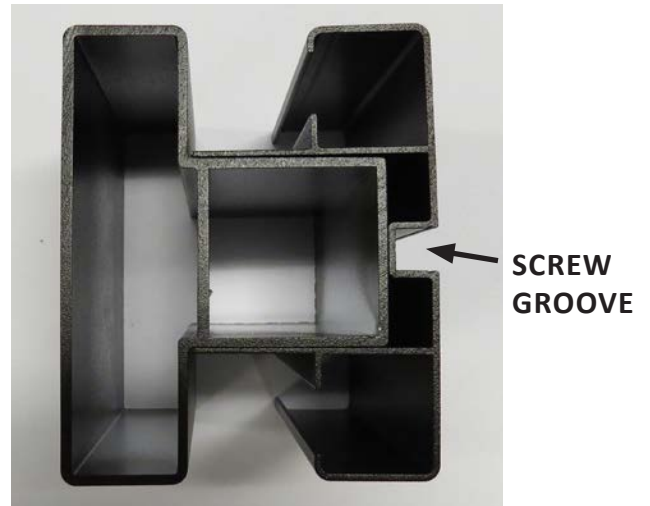
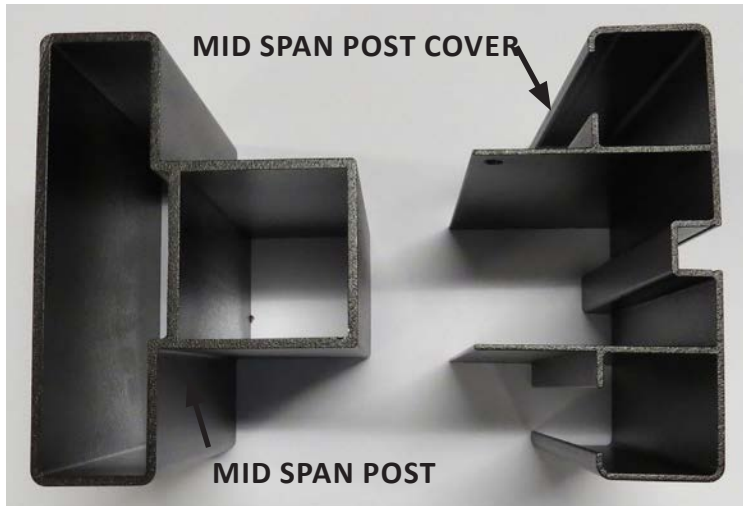

27. Use tek screws, in the screw groove, to secure cover to post



28. Attach post cap retainer and secure with tek screw



29. Attach the bottom of the post cap to the top of post and secure with Tek screws, then snap on top.



TOP VIEW

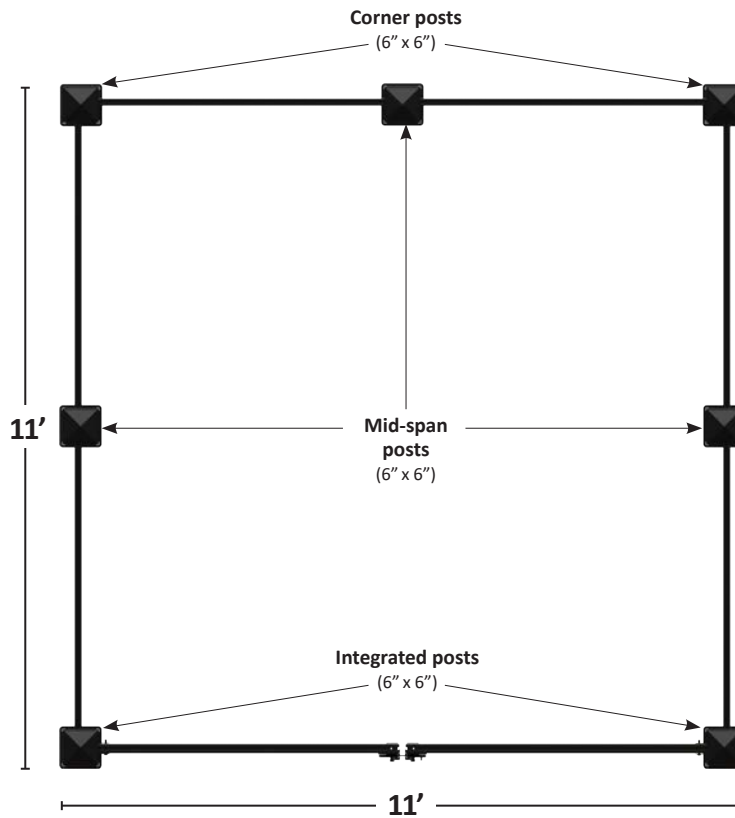

ISOMETRIC VIEW

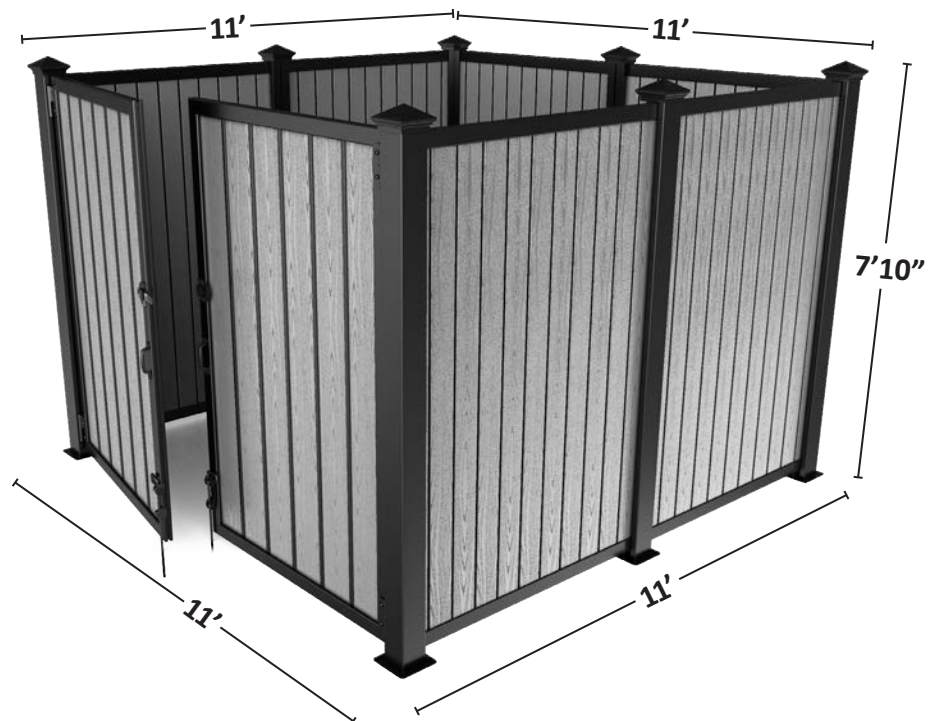

FRONT VIEW

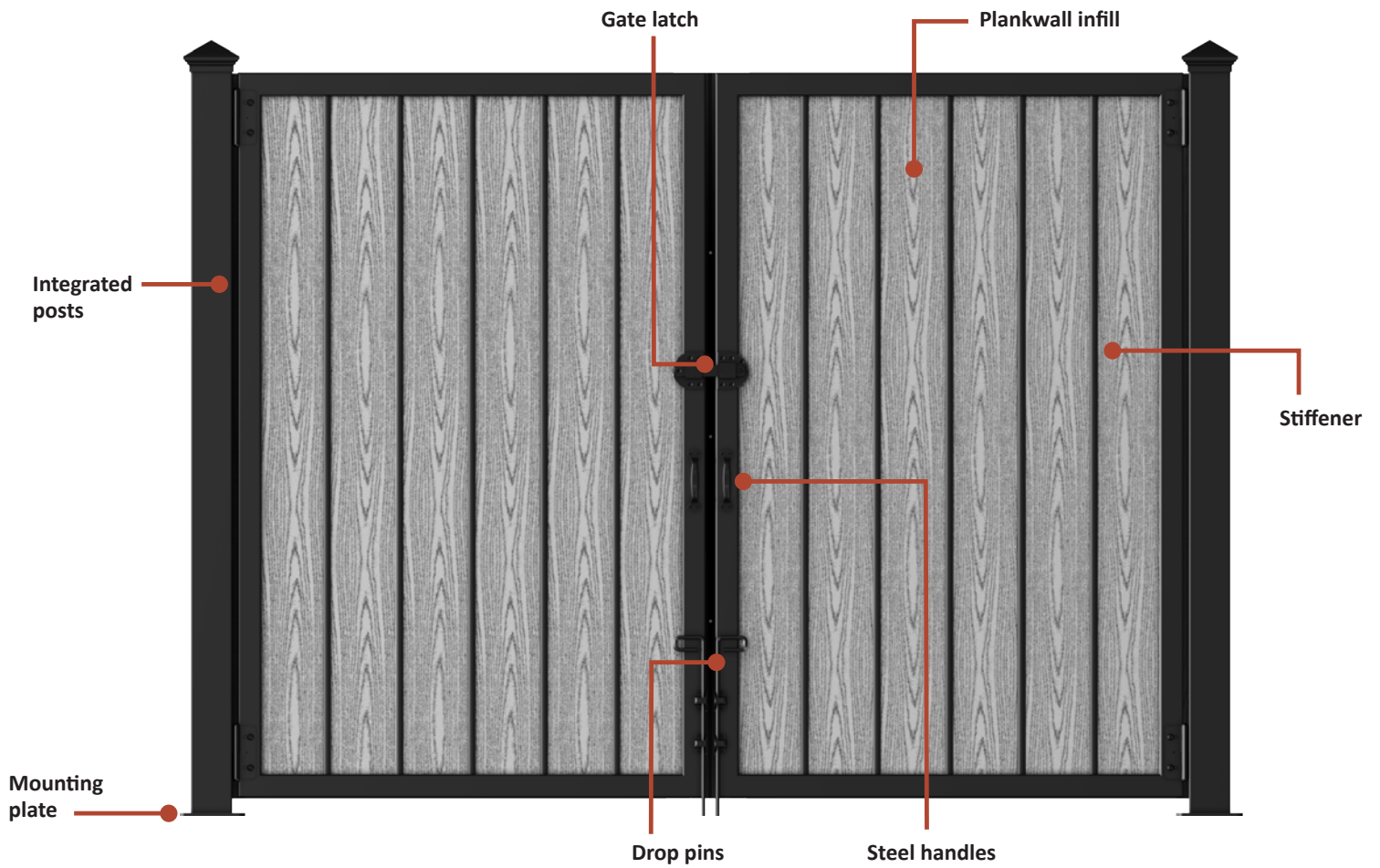

1. Attach hinges to integrated end posts
2. Take pre-assembled door and measure hinge placement
3. Drill hinge holes

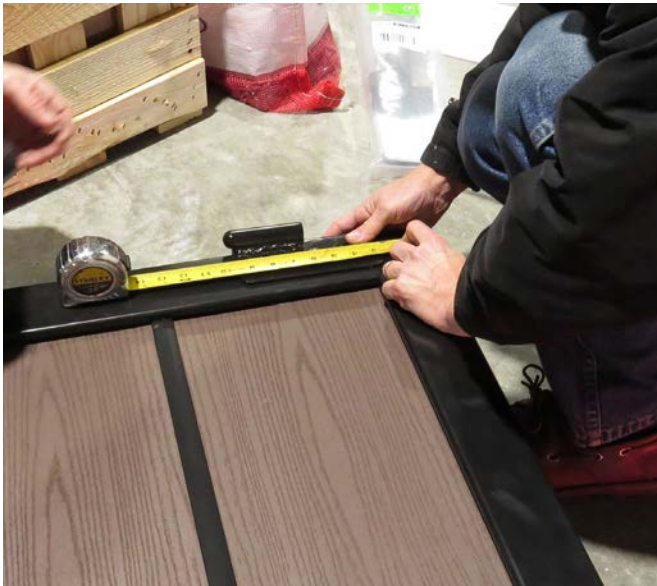

4. Line hinge up over holes and attach hinge to door (Repeat steps 1-4 for remaining hinges)

5. Attach Handles to door



6. Attach door to Integrated posts (Repeat steps 1-6 for remaining doors)

