

## Vertical Style Rooftop Equipment Screens

### Design and Assembly

Envisor components are designed to function as an Equipment Screening System. "Modular by Design" allows for a more user-friendly installation. This instruction packet is intended to communicate the "typical" Envisor screen installation. As you will see in the following pages, rooftop units (RTUs) vary greatly in size, performance accessories, and power supply requirements. Each screen ships as a knockdown assembly, with project specific parts lists and instruction supplements. Please review these pages carefully. We encourage you to call, fax or e-mail your questions and thank you for your interest in Envisor equipment screens.

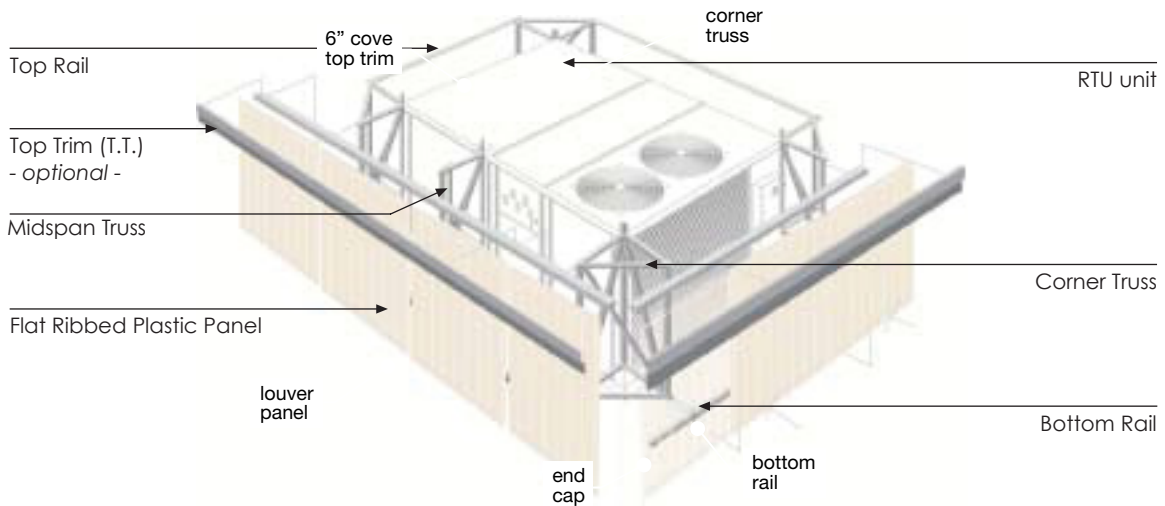

By CityScapes International, Incorporated  
4200 Lyman Court, Hilliard, OH 43026  
Phone: 614.850.2549, Fax: 614.850.2553, Toll Free: 877.727.3367  
[www.cityscapesinc.com](http://www.cityscapesinc.com)

## Vertical Style Rooftop Equipment Screens

### RTUs Installation Variables

Rooftop units (RTUs) are manufactured in a wide variety of sizes and shapes, with many different applications. Typically the project's architect, mechanical contractor or building owner will have exact information on the HVAC equipment manufacturer(s) specified, i.e. Aeon, Carrier, Hussman, Lennox, Trane, York, etc. A common point of reference to identify the physical size of the RTU equipment involved is "tonnage", i.e. 3-4 ton unit or a 75 ton unit.

Additional variables to be considered when screening a RTU with Envisor components have been depicted below. As with most field-installed products, the most complete information in the bid process will minimize any surprises during actual installation.



### Typical Installation of a 10 ton HVAC RTU

- A). Electrical Disconnect Box position should allow for a 1.5" minimum set back from the cabinet's corner.
- B). Supply lines such as Gas and Electric need to be installed as close to the roof deck as possible.
- C). Average Curb height above the roof deck is approximately 10". Curb heights more or less than this range should be noted and communicated.



### Typical Cabinet Drip Edge Condition

Most RTU cabinets will have a fabricated drip edge for rain at the top of the unit. Any accessories or obstructions other than this typical condition shown should be noted.  
(Compare to non-typical drip edge condition below)



## Vertical Style Rooftop Equipment Screens

---

### RTUs Installation Variables, continued



#### Economizer with Power Exhaust

The maximum distance that a corner truss can accommodate is 34" without additional support bracing.

---

**Note:** The images and conditions shown on pages 2 and 3 are representative of some potential variations that could effect the installation of an Envisor screen. Ultimately, any additional costs to accommodate conditions or equipment accessories that may require field modifications to Envisor components that were not anticipated will not be the responsibility of CityScapes International, Incorporated.

## Vertical Style Rooftop Equipment Screens

### CORNER TRUSS DETAILS

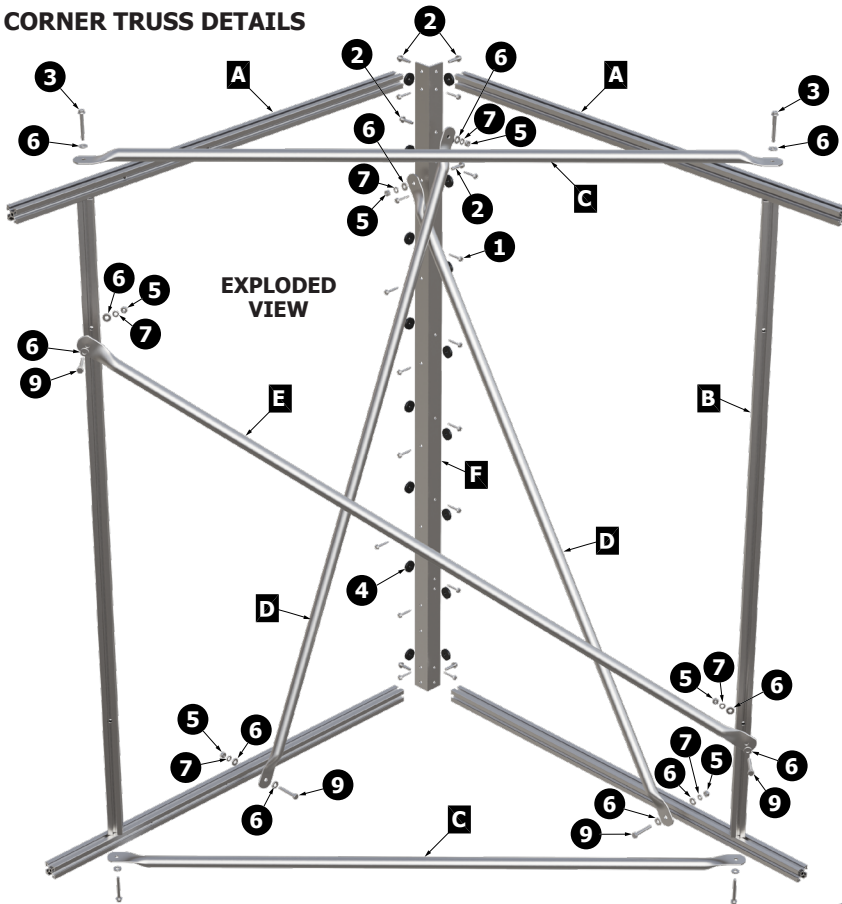

PARTS LIST		
ITEM	DESCRIPTION	QTY
A	XFRAME	4
B	XFRAME	2
C	Flat Tube Support	2
D	Flat Tube Support	2
E	Flat Tube Support	1
F	ANG AL 1/8" x 1-1/2" x 1-1/2"	1
1	Tek Screw	16
2	1" Bolt	6
3	2" Bolt	4
4	Rubber Spacer	16
5	Hex Nut	6
6	Flat Washer	16
7	Split Lockwasher	6
9	1-3/4" Bolt	4



1. Attach parts **A** to part **F** using 1" bolts.
2. Attach parts **B** and **C** to parts **A** using 2" bolts with flat washers.
3. Attach parts **D** to part **F** using 1" bolts, flat washers, lock washers, and hex nuts.
4. Attach parts **D** to parts **A** using 1-3/4" bolts, flat washers, lock washers, and hex nuts.
5. Attach part **E** to parts **B** using 1-3/4" bolts, flat washers, lock washers, and hex nuts.
6. Attach rubber spacers around remaining holes on back side of part **F**.

## Vertical Style Rooftop Equipment Screens

### MIDPAN TRUSS DETAILS

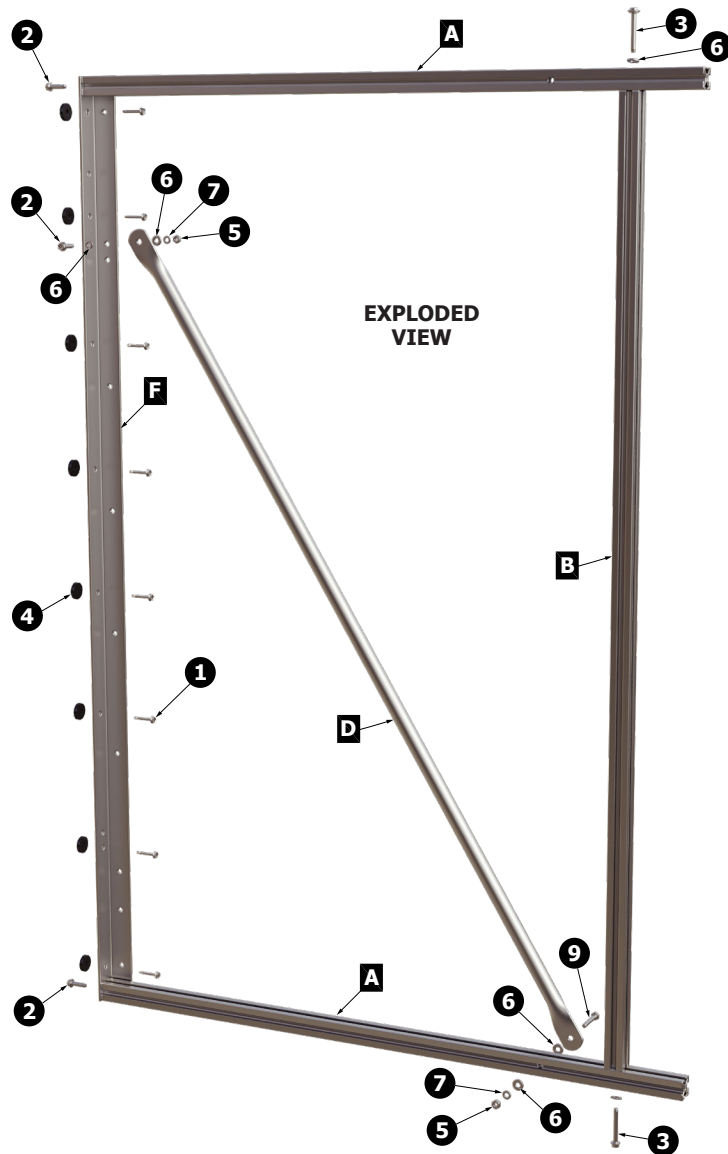

PARTS LIST		
ITEM	DESCRIPTION	QTY
A	XFRAME	2
B	XFRAME	1
D	Flat Tube Support	1
F	ANG AL 1/8" x 1-1/2" x 1-1/2"	1
1	Tek Screw	8
2	1" Bolt	3
3	2" Bolt	2
4	Rubber Spacer	8
5	Hex Nut	2
6	Flat Washer	6
7	Split Lockwasher	2
9	1-3/4" Bolt	1



1. Attach parts **A** to part **F** using 1" bolts.
2. Attach part **B** to parts **A** using 2" bolt with flat washer.
3. Attach part **D** to part **F** using 1" bolt, flat washers, lock washer, and hex nut.
4. Attach part **D** to part **A** using 1-3/4" bolt, flat washers, lock washer, and hex nut.
5. Attach rubber spacers around remaining holes on back side of part **F**.

## Vertical Style Rooftop Equipment Screens

### Getting Started

1. If there are multiple RTUs, be sure to match the correct Envisor screening components to the appropriate equipment. Component cartons will be labeled with a **Sales Order No.**, and the RTU's **Manufacturer**, with the **Model No.** of the RTU on which they are designated to be installed.
2. All units have their own layout drawings included with the installation instructions. Review the RTU's Adjacent Perimeter Area for obstructions or supply lines that may engage the screening components during installation. If our Design Engineers made allowances for any field conditions prior to shipment, the Job Specific installation instructions will identify any Equipment Specific Midspans or Extensions for your Envisor screen(s).
3. Locate the cartons marked "**Corner Truss Kit**". These items have been sent as a "Knockdown Kit" and will require field assembly prior to the installation of other Envisor components.
4. Check the RTU for "Square" and "Level" before proceeding to **Step 1** on the following page.

### Required Tools

Level	Reciprocating Saw (with metal cutting blades)	3/8" Socket
Tape Measure	#5/16" Drill Socket (nut driver)	7/16" Socket
Framing Square	3/8" Combination Wrench	1/8" Drill Bit
Cordless Drill	7/16" Combination Wrench	5/16" Drill Bit
Power Miter Saw	Quick Clamps (optional)	

### Envisor Components

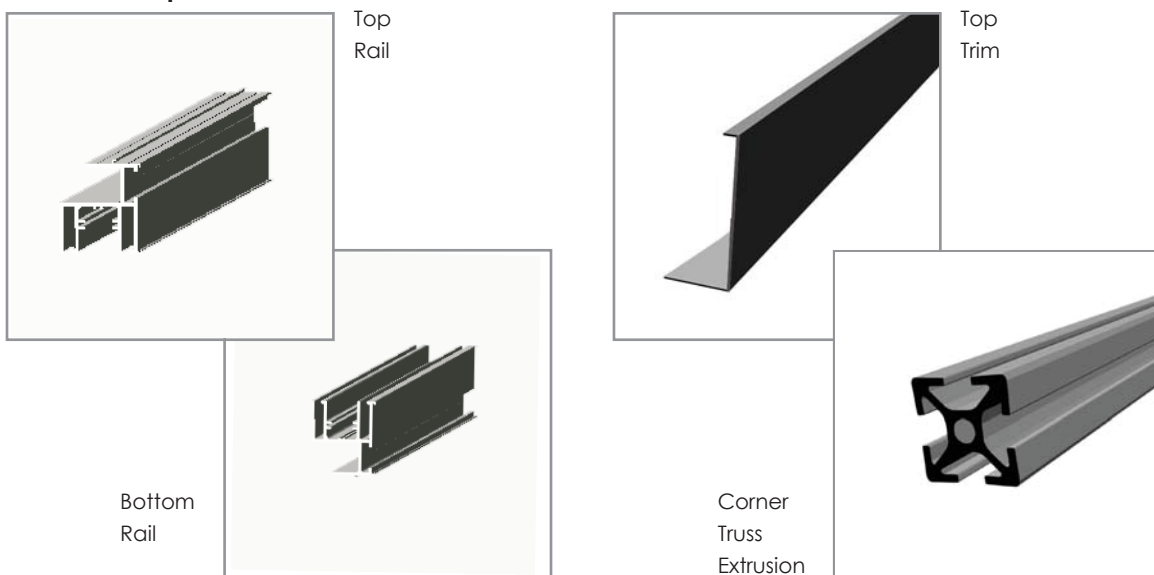

By CityScapes International, Incorporated  
4200 Lyman Court, Hilliard, OH 43026  
Phone: 614.850.2549, Fax: 614.850.2553, Toll Free: 877.727.3367  
[www.cityscapesinc.com](http://www.cityscapesinc.com)

## Vertical Style Rooftop Equipment Screens

---

### Step 1: Corner Truss

After verifying you have the correct **Corner Truss** for this RTU, review the **Unit Specific installation instructions** for additional **Extensions** or **Midspan Trusses** that may be required for this specific RTU. Be sure to install these components in the proper locations before attaching the **Corner Trusses**. See Extension & Gusset pictures below.

**Extensions, Gussets, Midspan Trusses** and **Corner Trusses** all attach to the RTU with stainless steel TEK screws provided in the Hardware Kit. The optimum vertical location for the Corner & Midspan Truss assemblies is approximately 4" above the top of the RTU. *This distance between bottom of screen and roof top will vary depending on the equipment's curb height and allowances for perimeter obstructions.* Be sure to level each component to the other as installation progresses around the perimeter of the RTU. See leveling picture.

**NOTE:** Use **EXTREME CAUTION** when attaching these first components to the RTU with the stainless steel TEK screws.

Some equipment may have mechanical operating elements directly behind the areas you are about to drive a screw into (i.e. condensing coils, etc.)

**Be absolutely sure that you are not about to penetrate any of these elements, or impede any access to Service Doors or Disconnect Switches.**

Reference photos below and on next page.



EXTENSION INSTALLATION



GUSSET INSTALLATION

By CityScapes International, Incorporated  
4200 Lyman Court, Hilliard, OH 43026

Phone: 614.850.2549, Fax: 614.850.2553, Toll Free: 877.727.3367

[www.cityscapesinc.com](http://www.cityscapesinc.com)



CORNER TRUSS INSTALLATION



LEVELING THE COMPONENTS

By CityScapes International, Incorporated  
4200 Lyman Court, Hilliard, OH 43026  
Phone: 614.850.2549, Fax: 614.850.2553, Toll Free: 877.727.3367  
[www.cityscapesinc.com](http://www.cityscapesinc.com)



## Vertical Style Rooftop Equipment Screens

### Step 2: Install Bottom Rail (B.R.)

Temporarily position all of the bottom rail as indicated in the diagram below. If any of the dimensions on your RTU are longer than the longest **B.R.**, you will need to splice two lengths together. See Detail A on next page.

Beginning at one corner, use a framing square to align **B.R.** to the installed **Corner Truss** on the RTU. This first end of the **B.R.** should be flush and square with the **Corner Truss**. Assure the alignment and placement of the rail in respect to the pilot hole located in the center of the extrusion on the **Corner Truss** leg. Mark this location and drill a hole with the 5/16" drill bit. Using 1/4"-20 x 1" self tapping screw, fasten through **B.R.** into the **Corner Truss** leg extrusion pilot hole. See illustration and detail photo below.

Continue installing the **B.R.** at alternating legs of the **Corner Truss** around the perimeter of the RTU, making sure each **Corner Truss** is square to the **B.R.** before drilling and fastening. Install the remaining four corners as above, additionally checking the lengths of the **B.R.** on the opposing side of the RTU for equal distances. Then cut the excess lengths of the **B.R.** with a reciprocating saw. See Detail B on next page.

After all four corners have been trimmed, insert the **Corner Splice** (appx. 6" length of extrusion) into the bottom "C" cavity of the **B.R.** Secure the **Corner Splice** in place with the 1 1/4" TEK screws. See Detail C on next page.

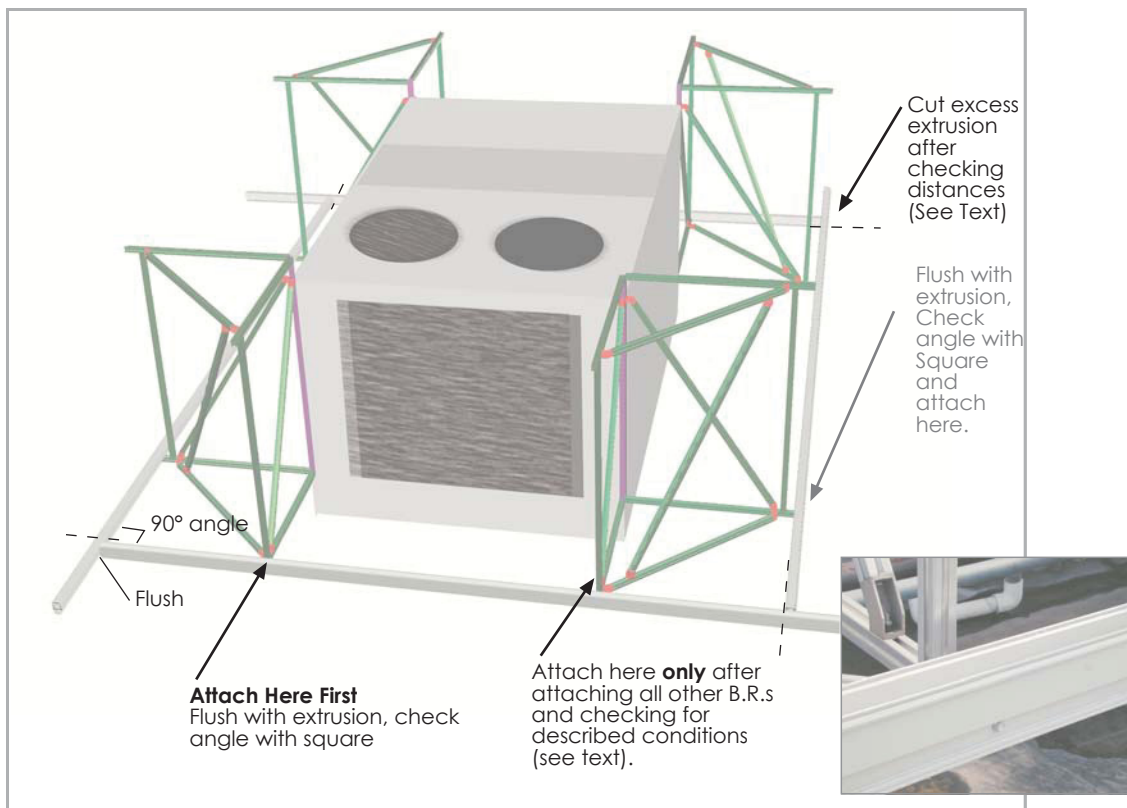

## Vertical Style Rooftop Equipment Screens

### Step 2: Install Bottom Rail (B.R.) continued

Detail A

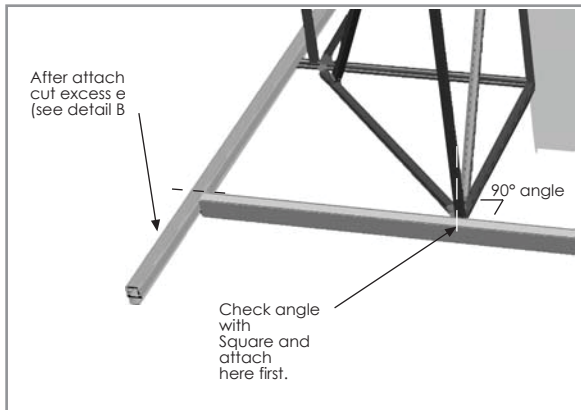
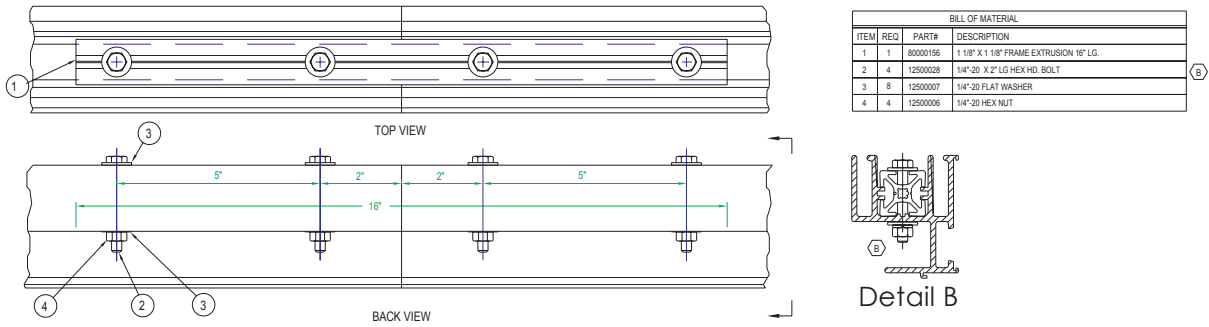

END SECTION VIEW

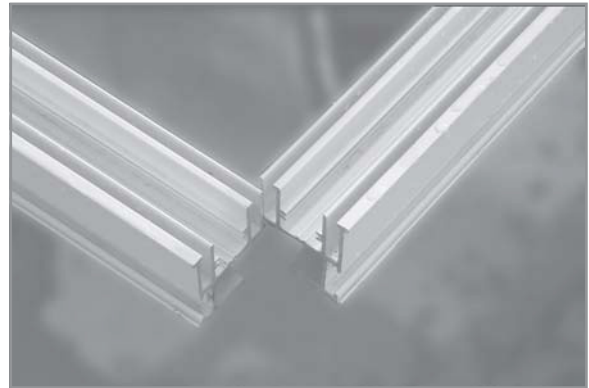

Detail C

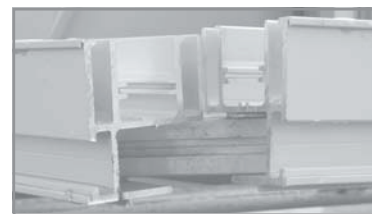
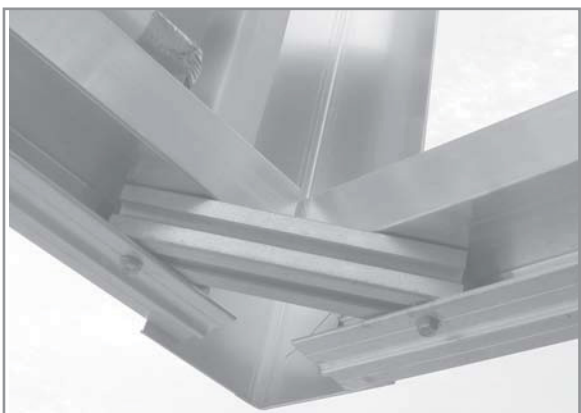

Front View

Back View

## Vertical Style Rooftop Equipment Screens

---

### Step 3: Install Top Rail (T.R.)

The **Top Rail (T.R.)** installs exactly the same as the **Bottom Rail**.

It is important to maintain close tolerance cuts when field trimming the **B.R.** and **T.R.** to insure the **Corner Splice** fully engages both extrusions.

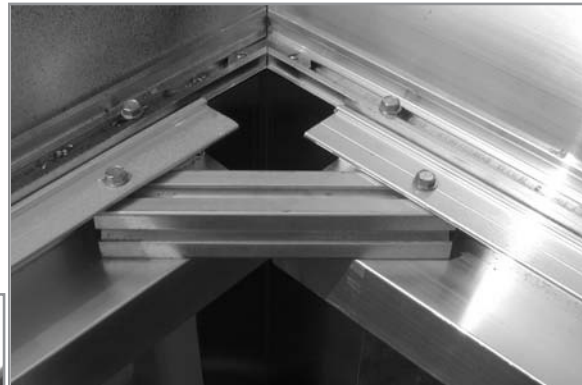
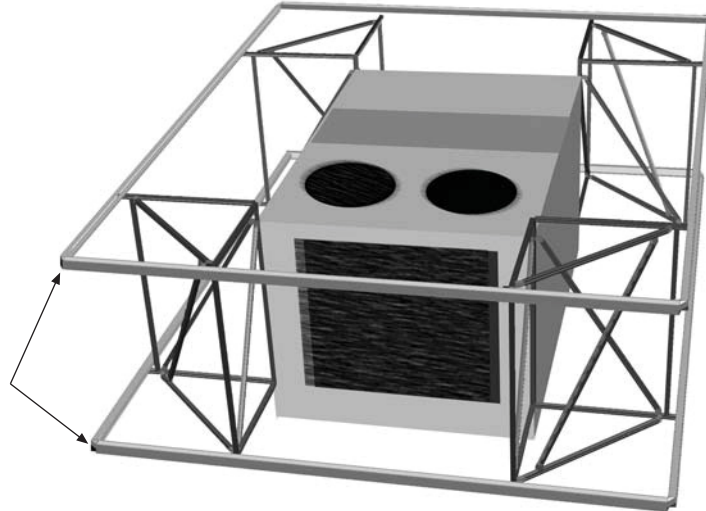

## Vertical Style Rooftop Equipment Screens

### Step 4: Place Stabilizer Braces

NOTE: Omit this step if unit is screened on 4 sides.

Place the **Stabilizer Braces's** End Casting over the central slot of the outer side of the bottom leg of the **Corner Truss**. Slide End Casting until the Brace's opposite end (no End Casting) is inside the mounting slot of the **B.R.**

Next, using a 5/16" drill bit, drill through both the End Casting of Brace and bottom leg of Corner Truss and attach the parts with supplied bolt using drilled hole as a guide (see Photo 1).

Then, lock the **Stabilizing Brace** in place by attaching it to the **B.R.** using a 1 1/4" Tek screw (drill first through the bottom of the B.R.'s mounting slot as shown in photos 2 & 3).

**DO NOT BLOCK SERVICE DOORS.**

Finally, place the other three **Stabilizer Braces** as shown below.

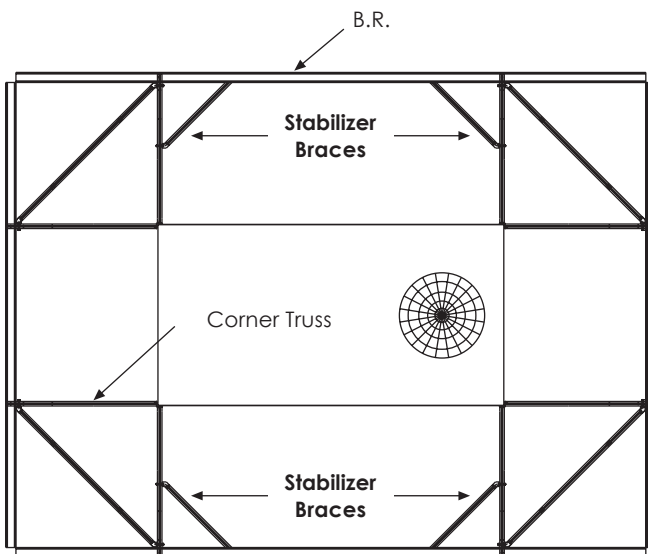

Bottom View of RTU with Stabilizer Braces in place

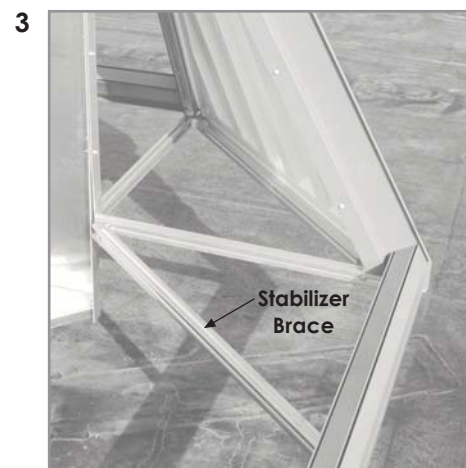
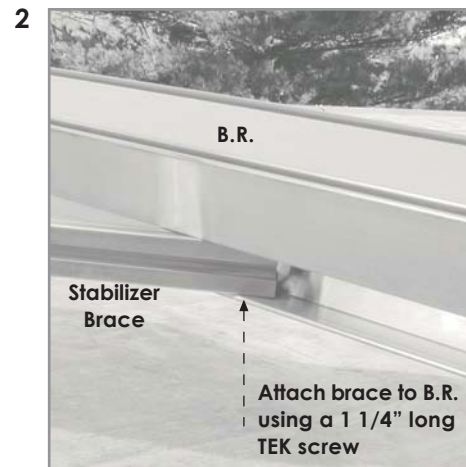
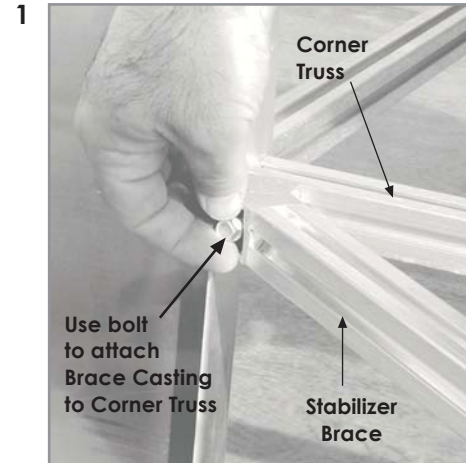

## Vertical Style Rooftop Equipment Screens

### Step 5: Install Top Trim (T.T.) 4" & 8" flat

**Please note: Top Trim is an optional system component. If Top Trim was not ordered proceed to Step 7.**

The **Top Trim (T.T.)** is a fabricated aluminum component that attaches to the **T.R.** with 1 1/4" long stainless steel TEK screws.

Temporarily position two pieces of **T.T.** at a corner. Extend them beyond the **T.R.** extrusion until they meet. Before cutting the **T.T.** to length with a power miter saw, measure the length of each piece of **T.T.** to be sure it will be the exact size required to fit both corners. Cut to length and install the **T.T.** into the **T.R.** with the TEK screws approximately 12" on center.

#### Detail A

At the top of each corner install a 1/8" rivet where the two pieces of **T.T.** overlap. Attach the self-adhesive Top Trim Corner Angle to the insides of the **T.T.** as shown.

When the equipment screen requires more than one length of **T.T.** per side splice as shown.

When installation of **Top Trim** is complete use the provided touch-up paint to cover any exposed edges, screws and rivets.

Reference photos on following page.

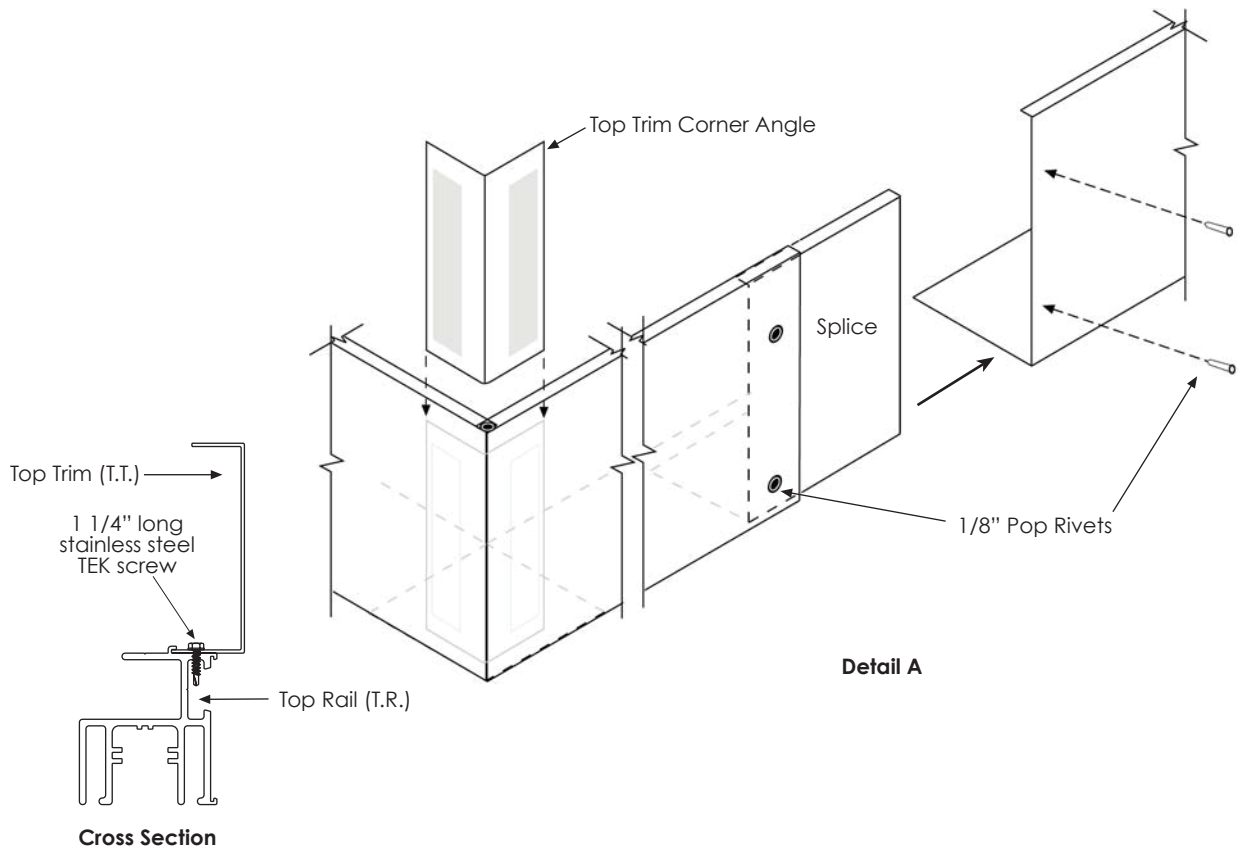

## Vertical Style Rooftop Equipment Screens

---

### Step 5: Install Top Trim (T.T.) 4" & 8" flat

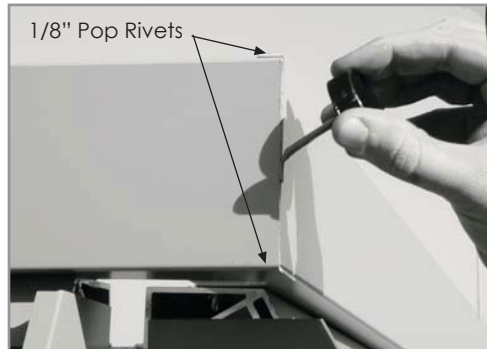

## Vertical Style Rooftop Equipment Screens

### Step 5: Install Top Trim (T.T.) Cove or Alamo.

The **Top Trim (T.T.)** is fabricated aluminum components that attaches to the **T.R.** with 1 1/4" long stainless steel TEK screws.

Position the Corner Pieces **T.T.** at each corner (as required), and attach them to the **T.R.** with Tek screws. Before cutting the Straight Section of **T.T.**, measure the distance between the two Corner Pieces of **T.T.** Cut to length using a power miter saw.

Join the Straight Section **T.T.** to the Corner Piece **T.T.** with the Top & Bottom Keys as well as the Splices, secure with Tek screws and 1/8" rivets.

When Installation of **T.T.** is complete use the provided touch-up paint to cover any exposed edges, screws and rivets.

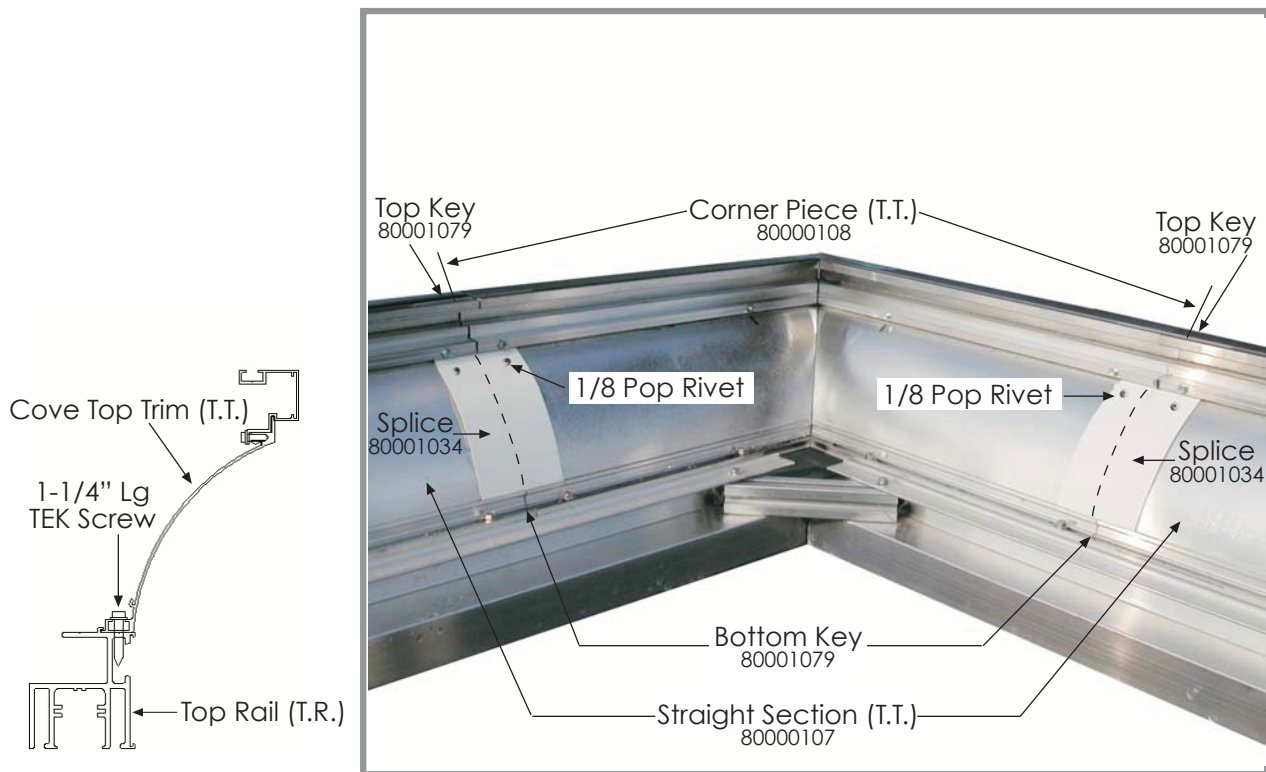

## Vertical Style Rooftop Equipment Screens

### Step 5: Install Top Trim (T.T.) 3" Flat, Step1, Step2 (Shown)

The **Top Trim (T.T.)** is fabricated aluminum components, that attaches to the **T.R.** with 1 1/4" long stainless steel TEK screws.

Position the Mitered LH Corner Piece **T.T.** with the Mitered RH Corner Piece **T.T.** at each corner (as required), and attach them to the **T.R.** with the Tek screws. Before cutting the Straight Section of **T.T.**, measure the distances between the two Corner Pieces of **T.T.** to make sure the Straight Section **T.T.** will fit exactly between the two Corner Pieces of **T.T.** Cut to length using a power miter saw.

Join the Straight Section **T.T.** to the Corner Piece **T.T.** with the Top & Bottom Keys as well as the Splices, secure with Tek Screws and 1/8" rivets.

When installation of **T.T.** is complete use the provided touch-up paint to cover any exposed edges, screws and rivets

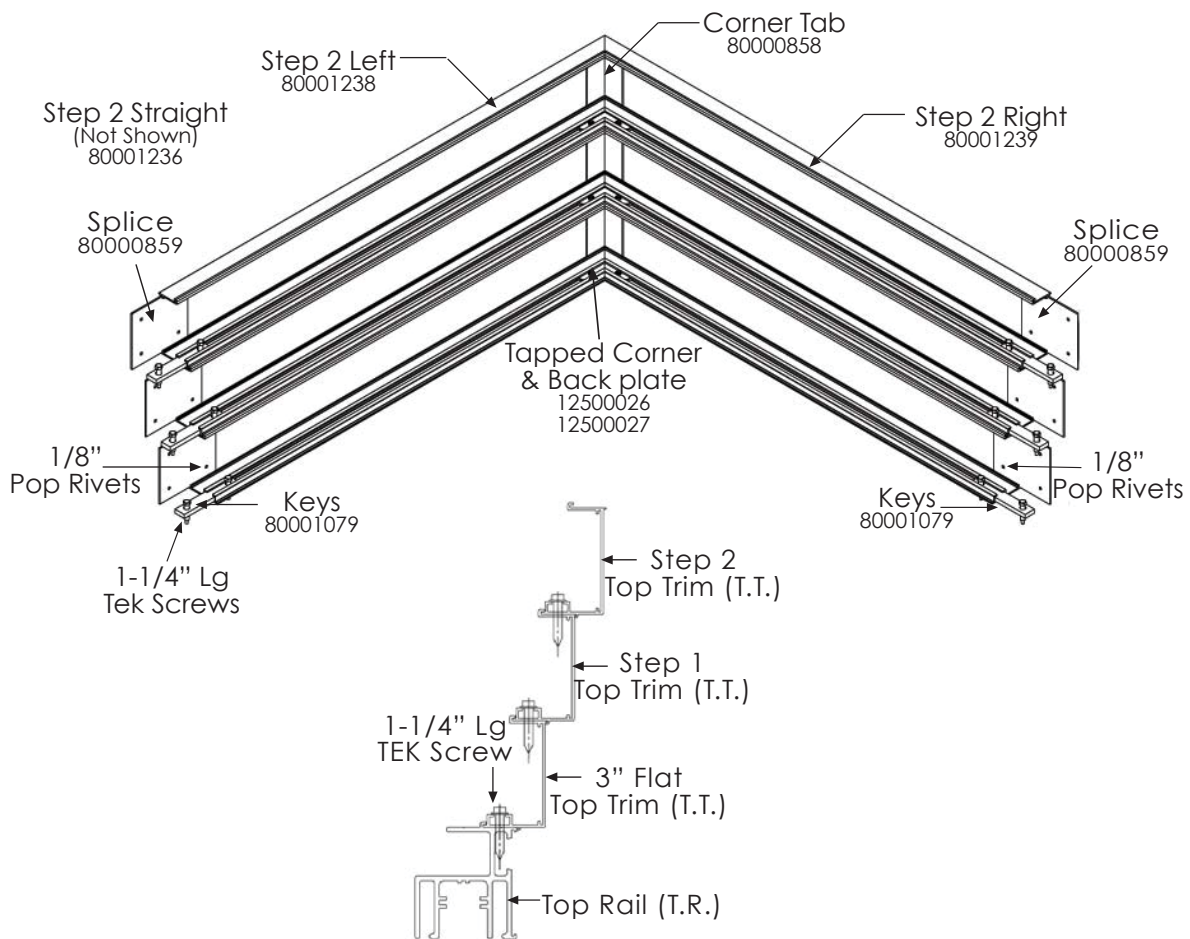

By CityScapes International, Incorporated  
4200 Lyman Court, Hilliard, OH 43026  
Phone: 614.850.2549, Fax: 614.850.2553, Toll Free: 877.727.3367  
www.cityscapesinc.com



## Vertical Style Rooftop Equipment Screens

### Step 6: Install Plastic Panels

The quantity and position of the **Plastic Panels** will vary with each RTU. Refer to unit specific **installation instructions** for panel layout. There are only two panel widths (22 1/2" and 45"). The overlap between the front and back panels will vary approximately 2" to 6".

When installing the panels into the **Top** and **Bottom Retainers**, slide the panels between the front and back channel. This will allow the panels to slide one behind the other for **Service Access** to the RTU.



By CityScapes International, Incorporated  
4200 Lyman Court, Hilliard, OH 43026  
Phone: 614.850.2549, Fax: 614.850.2553, Toll Free: 877.727.3367  
[www.cityscapesinc.com](http://www.cityscapesinc.com)

## Vertical Style Rooftop Equipment Screens

---

### Step 7: Install End Caps

With all of the **Plastic Panels** installed, begin at one corner with an **End Cap**, and position it flush over the ends of both the **T.R.** and **B.R.** Use the 1/1/4" long stainless steel TEK screws to attach the **End Caps** to the Retainer extrusions at top and bottom.



## Vertical Style Rooftop Equipment Screens

---

### Step 8: Final Details

Installing the End Caps completes the last component assembly step.

Next, locate the blue and white label in your hardware carton that says "NOTICE" at the top. This label should be placed on the outside surface of the panel that has the RTU's Disconnect Switch located behind it. Remove the backing from the label and apply it to this panel so that it is plain view.

Also inside the hardware carton you will find small white plastic bottles of "touch up" paint in the same color as your Envisor Screen. This paint should be used to touch up any small panel scratches or screw heads that may have had the painted surface damaged during installation.

Finally we recommend walking around the entire RTU's screen to inspect and make any adjustments in the position of the panels. Sliding plastic panels left or right for even spacing will complete your installation.



---

If you have any questions about the installation of the Envisor system  
we encourage you to call us at **1 877 727 3367**

By CityScapes International, Incorporated  
4200 Lyman Court, Hilliard, OH 43026  
Phone: 614.850.2549, Fax: 614.850.2553, Toll Free: 877.727.3367  
[www.cityscapesinc.com](http://www.cityscapesinc.com)